

CBRE

Retail

Propiedad Comercial en Renta

1,119 m²

de área rentable con opción
a subdividirse

Shakespeare 164, Anzures, Miguel Hidalgo, 11590
Ciudad de México, CDMX



Características



Entrada por
Lafayette y
Shakespeare



Amplio
estacionamiento



Uso de suelo
mixto



Elevado flujo
vehicular



Amplia
exposición con
3 frentes



Ideal para cualquier
giro de servicio o
comercio



Planta de Conjunto

1,119 m² 

de área rentable con opción a subdividirse

CUADRO DE CONSTRUCCION AREA 2					
LADO EST	PV	RUMBO	DISTANCIA	V	COORDENADAS X Y
1	2	N 31°36'48.01" W	8.043	2	2,146,224.210 479,287.854
2	3	S 47°02'42.17" W	8.882	3	2,146,227.471 479,275.446
3	4	S 39°36'42.71" W	2.768	4	2,146,225.540 479,273.873
4	5	S 91°23'42.17" E	6.787	5	2,146,220.070 479,280.724
5	1	N 59°51'30.00" E	8.240	1	2,146,224.210 479,287.854

SUPERFICIE = 84.267 m2

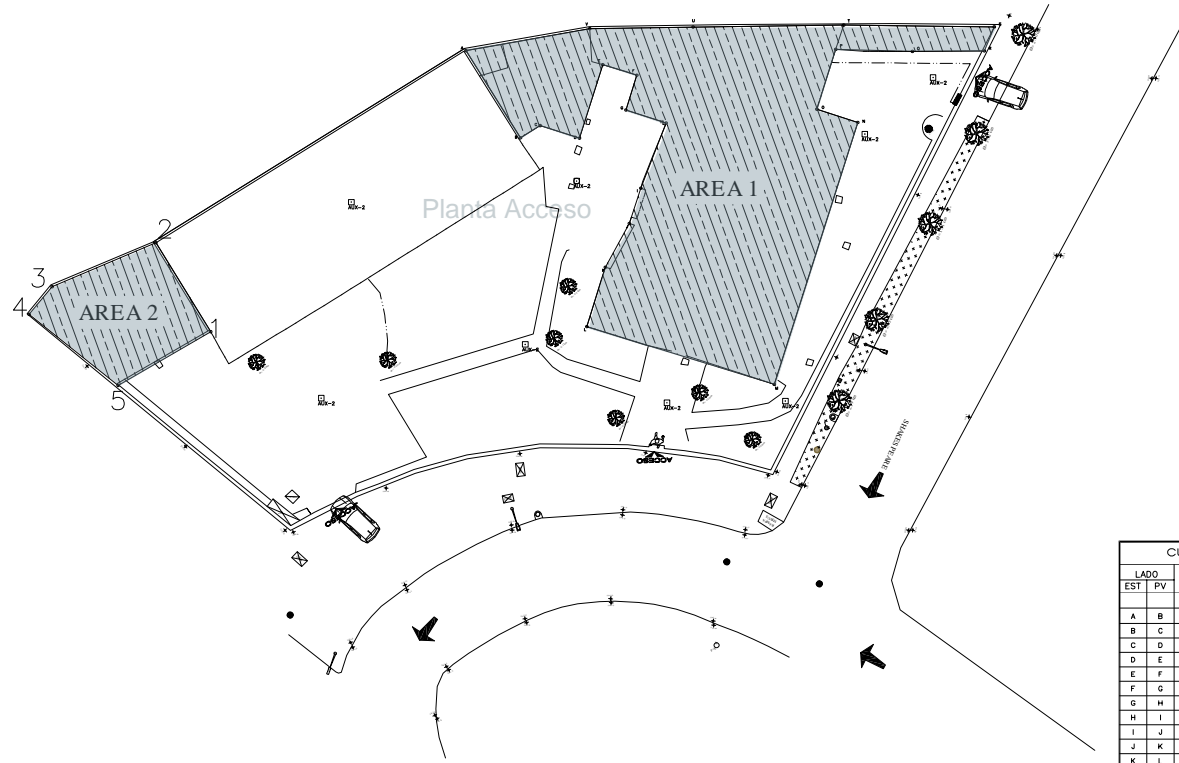

CUADRO DE CONSTRUCCION AREA 2					
LADO EST	PV	RUMBO	DISTANCIA	V	COORDENADAS X Y
A	B	S 31°58'48.01" E	7.916	B	2,149,246.701 479,307.586
B	C	N 30°07'13.00" E	1.783	C	2,149,238.980 479,311.779
C	D	S 72°39'47.33" E	3.185	D	2,149,238.982 479,316.331
D	E	N 17°37'14.67" E	5.913	E	2,149,244.618 479,318.121
E	F	S 72°52'41.47" E	2.725	F	2,149,243.818 479,320.726
F	G	S 18°56'20.37" W	3.855	G	2,149,241.136 479,319.807
G	H	S 72°13'14.28" E	3.248	H	2,149,240.144 479,322.998
H	I	S 21°42'32.51" W	5.398	I	2,149,235.114 479,321.039
I	J	S 17°46'19.00" W	2.898	J	2,149,232.380 479,320.166
J	K	S 28°59'05.77" W	3.834	K	2,149,229.041 479,318.308
K	L	S 17°18'09.04" W	4.781	L	2,149,224.475 479,316.880
L	M	S 72°49'17.00" E	15.101	M	2,149,220.025 479,331.317
M	N	N 17°39'09.80" E	21.154	N	2,149,242.173 479,333.133
N	O	N 71°58'54.55" W	3.304	O	2,149,241.195 479,334.591
O	P	N 17°31'36.33" E	4.828	P	2,149,245.799 479,336.045
P	Q	S 89°31'05.32" E	5.906	Q	2,149,245.846 479,341.849
Q	R	N 89°31'26.37" E	5.529	R	2,149,245.680 479,341.478
R	S	N 22°40'03.51" E	1.909	S	2,149,247.532 479,348.252
S	T	N 89°20'07.82" W	11.622	T	2,149,247.667 479,336.650
T	U	S 89°13'12.27" W	11.294	U	2,149,247.208 479,326.053
U	V	S 89°13'12.27" W	7.844	V	2,149,245.460 479,317.110
V	A	S 79°52'54.38" W	9.675	A	2,149,245.701 479,307.586

SUPERFICIE = 476.680 m2

CUADRO DE CONSTRUCCION ACTUAL.					
LADO EST	PV	RUMBO	DISTANCIA	V	COORDENADAS X Y
A	B	N 50°33'35.87" W	26.253	B	2,149,226.454 479,273.802
B	C	N 39°39'47.71" E	2.879	C	2,149,227.671 479,275.640
C	D	N 67°12'03.37" E	8.535	D	2,149,230.978 479,283.508
D	E	N 58°07'36.71" E	28.221	E	2,149,245.880 479,307.474
E	F	N 80°09'04.22" E	9.765	F	2,149,247.551 479,317.096
F	G	N 89°05'22.16" E	10.884	G	2,149,247.721 479,327.979
G	H	N 89°42'11.67" E	12.541	H	2,149,247.786 479,340.520
H	I	S 89°31'50.59" E	8.226	I	2,149,247.718 479,348.746
I	J	S 26°52'01.93" W	38.833	J	2,149,213.077 479,331.196
J	K	N 74°47'29.46" W	4.264	K	2,149,214.196 479,327.082
K	L	N 82°51'35.86" W	7.104	L	2,149,215.079 479,320.033
L	M	N 89°34'19.23" W	6.741	M	2,149,215.129 479,313.292
M	N	S 81°25'37.25" W	5.655	N	2,149,214.286 479,307.701
N	O	S 74°28'47.44" W	4.170	O	2,149,213.170 479,303.682
O	P	S 68°17'08.99" W	4.810	P	2,149,211.391 479,299.214
P	A	S 63°01'59.10" W	5.764	A	2,149,208.777 479,294.077

SUPERFICIE = 1,774.467 m2



Plantas Arquitectónicas

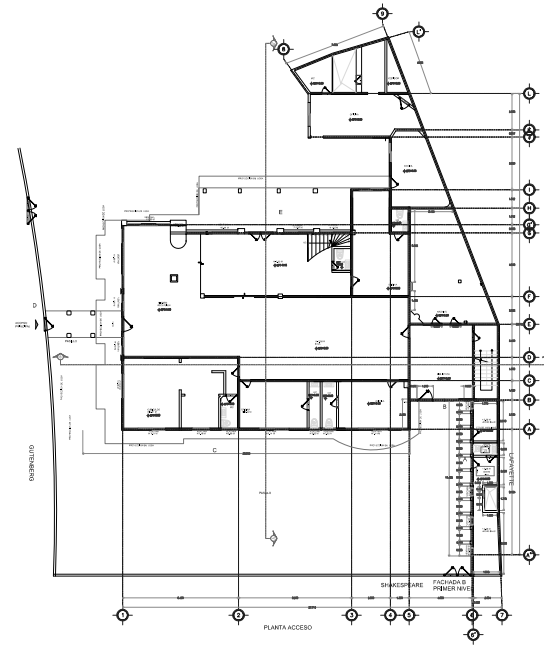

Planta Acceso

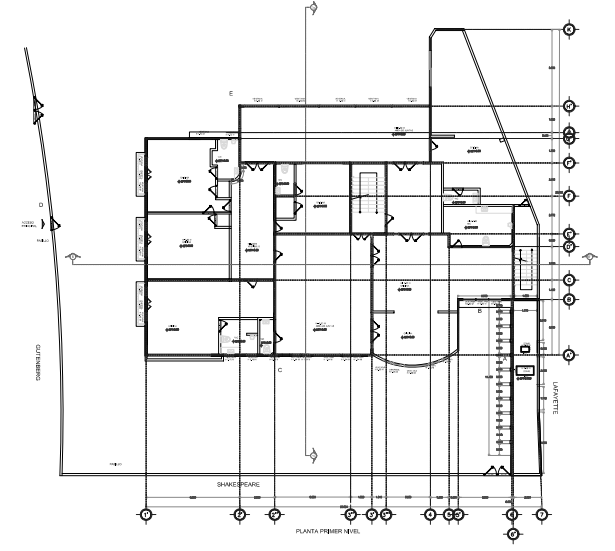

Planta Primer Nivel

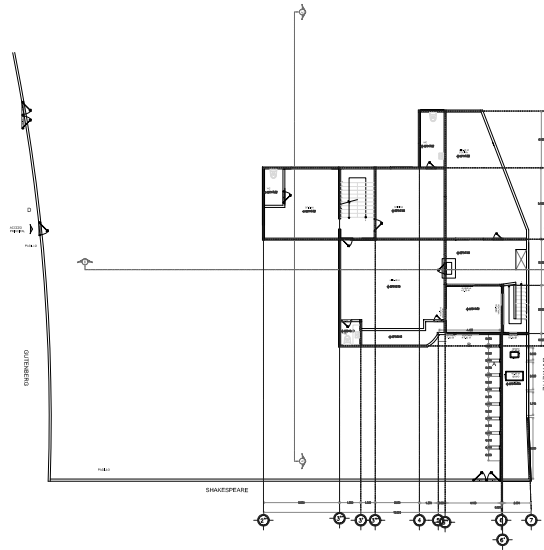

Planta Segundo Nivel

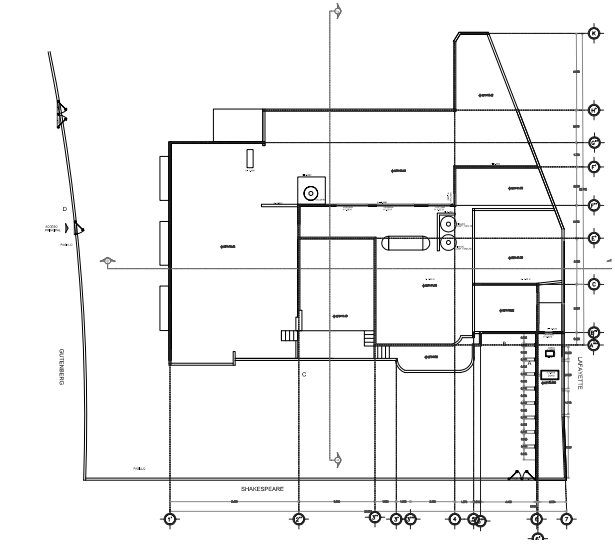

Planta Azotea

Planta Estacionamiento





Ubicación

Shakespeare 164, Anzures, Miguel Hidalgo, 11590 Ciudad de México, CDMX

1. La Propiedad
2. Liverpool Polanco
3. Camino Real Polanco
4. Honda Anzures
5. Plaza de las Estrellas

<https://goo.gl/maps/MA2q39cfFaLahYv47>

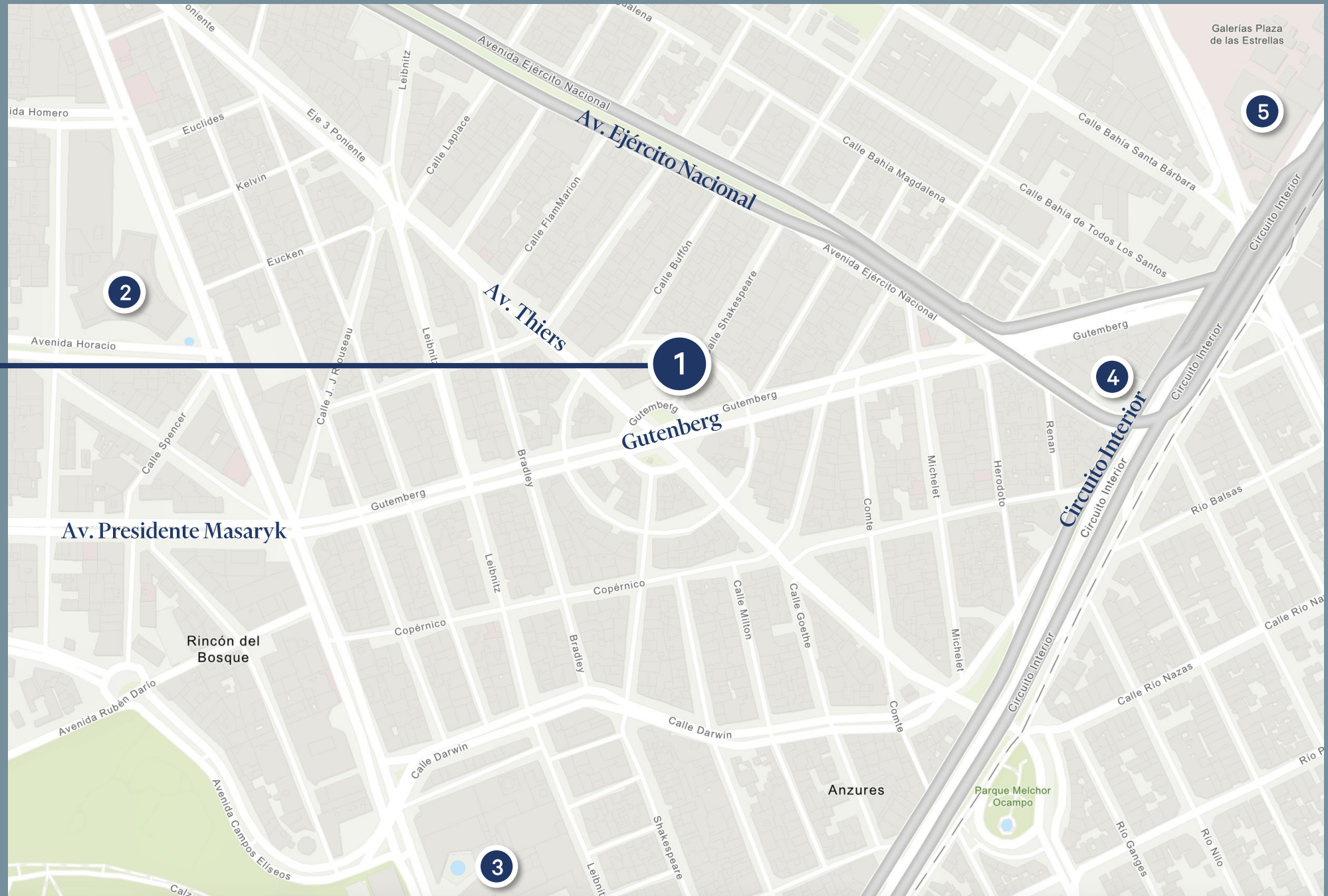

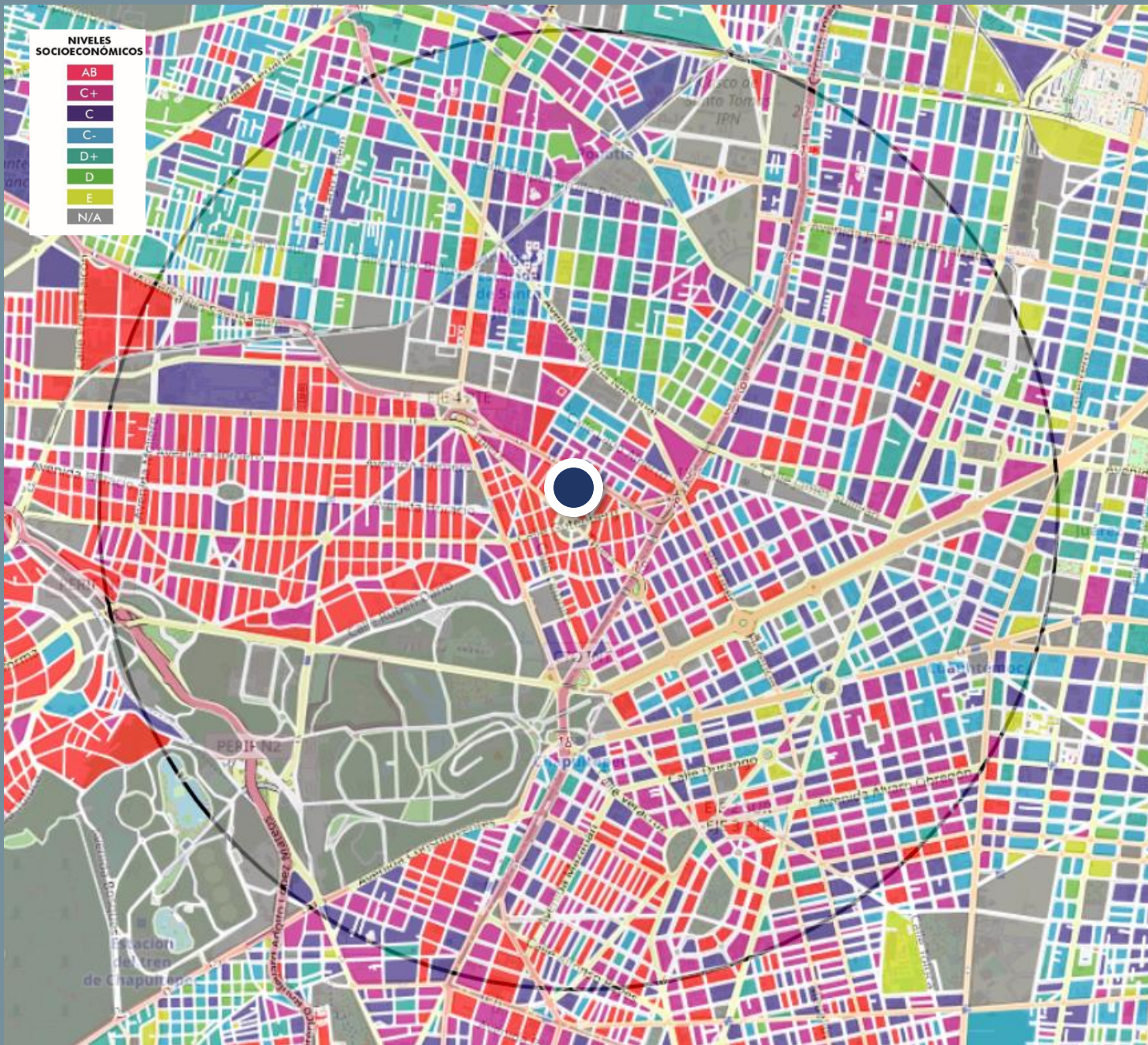

Información Demográfica

Información demográfica 3 km Radio

Población Total 3 Km	281,088
Población 0 a 20 (Centenials)	53,154
Población 21 a 41 (Millenials)	91,848
Población 42 a 56 (Gen X)	76,187
Población 57 a 75 (Baby Boomers)	38,147
+75 años	21,752
Hogares Totales	78,080

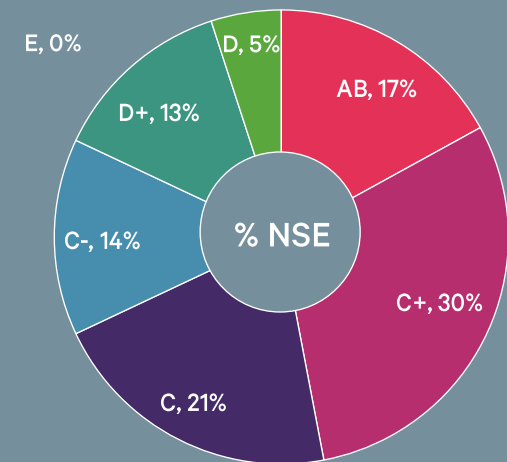



Para más información:

Fabiola Rodríguez de la Vega

T. (55) 8526 8884

Fabiola.Rodriguezdelavega@cbre.com

Aldo Martínez

T. (55) 5284 3291

Aldo.Martinez@cbre.com

© 2023 CBRE, Inc. All rights reserved. This information has been obtained from sources believed reliable, but has not been verified for accuracy or completeness. You should conduct a careful, independent investigation of the property and verify all information. Any reliance on this information is solely at your own risk. CBRE and the CBRE logo are service marks of CBRE, Inc. All other marks displayed on this document are the property of their respective owners, and the use of such logos does not imply any affiliation with or endorsement of CBRE. Photos herein are the property of their respective owners. Use of these images without the express written consent of the owner is prohibited.

